

INSTALLATION INSTRUCTIONS

Double Track Low Headroom Supplemental Instructions*

Things to Know Before You Begin



In the interest of safety this symbol means **WARNING** or **CAUTION**. Personal injury and/or property damage may occur unless instructions are followed carefully.

Minimum Headroom Required

Front Mount Torsion = 9½"

Extension = 4½"

Section 1 Attaching LHR Bottom Brackets to Door

Step 1

Steel Doors: Insert low headroom bottom bracket locking tabs into end stile key slots by pushing inwards and then up. The "L" and "R" letters on the brackets designate left hand and right hand brackets (inside looking out). Attach brackets to door using #14 x 5/8" sheet metal screws. (FIG. 1) Loop end of lift cable around button as shown.



WARNING

Failure to properly engage locking tabs on bottom bracket into key slots on edge of door can result in severe injury when spring tension is applied.

Wood Doors: Attach bottom brackets to door in the position shown in FIG. 1, VIEW B using ¼" - 20 x 1 7/8" carriage bolts & red coated nuts. The "L" and "R" letters on the brackets designate left hand and right hand brackets (inside looking out).

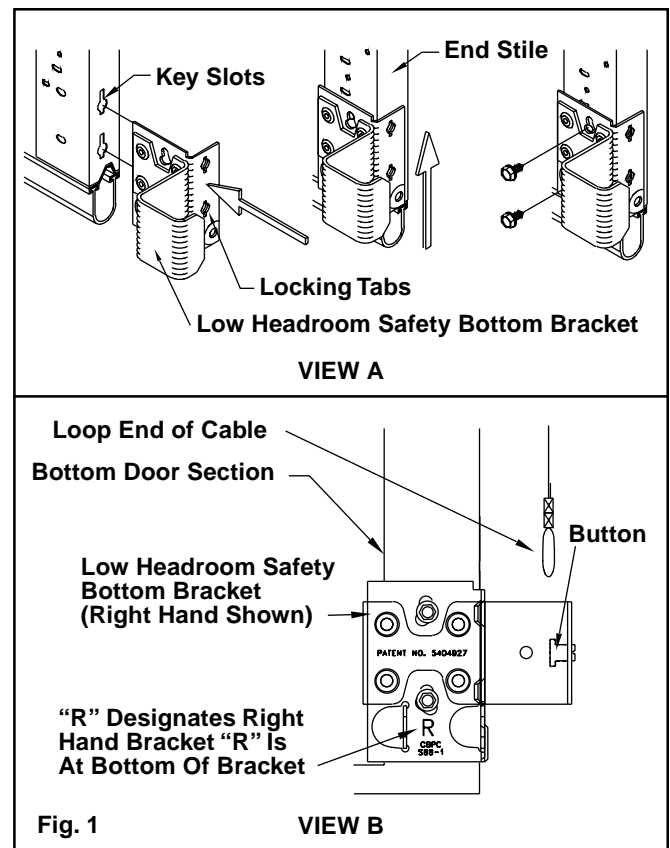

*Do not use for steel door over 250 lb. call hotline to verify door weight. Special bottom brackets and red coated fasteners are required.

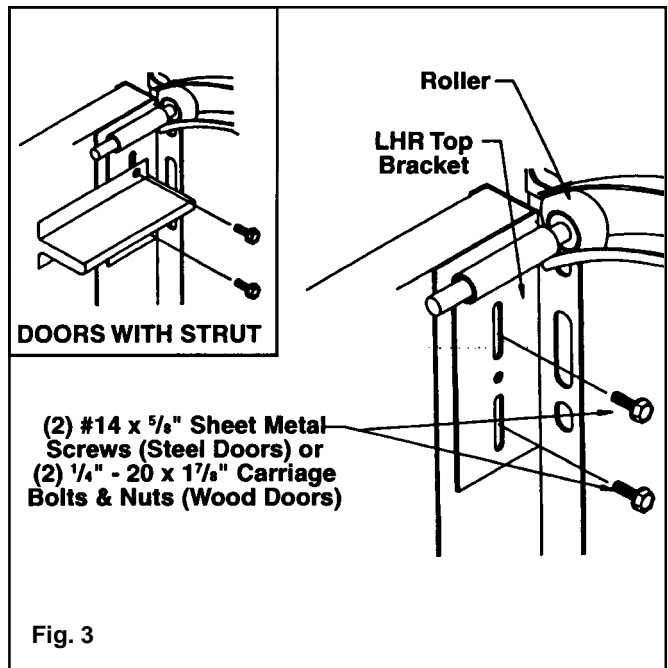
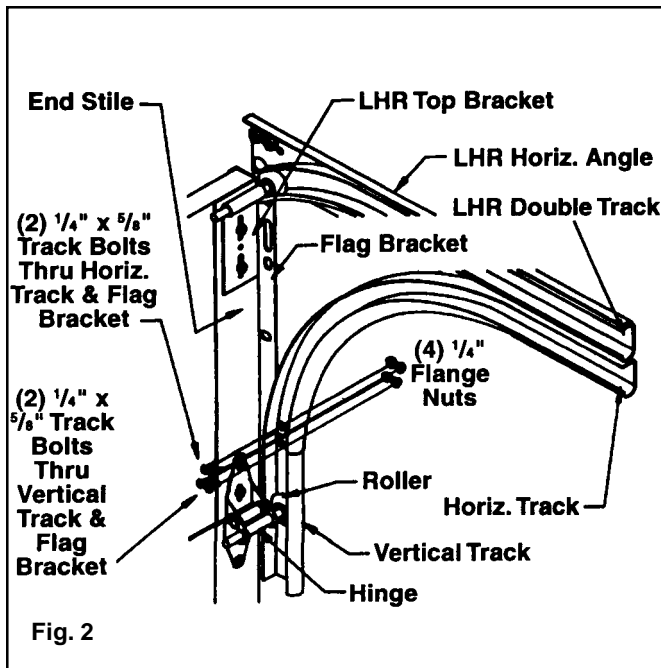

Step 2

Stack sections and attach vertical track to side jambs, as shown in the original instructions. Attach the horizontal track to the flag bracket (FIG 2) and hang the horizontal track as shown in the original instructions.

NOTE: If a top strut is to be installed on door, place top section on sawhorses and position strut on top section about 1" from the top of door. At each stile location drill $\frac{5}{32}$ " pilot holes through strut and stile, using care not to go through the section. Attach strut to door (**at center stiles only**) using #14 x $\frac{5}{8}$ " sheet metal screws (steel doors) or $\frac{1}{4}$ " x 1" lag screws (wood doors). **DO NOT attach strut at end stile locations at this time, as it will be necessary to place LHR top bracket between strut and door in the next step.**

Step 3

Insert rollers in low headroom top brackets. On each side of door, insert each roller into horizontal track. Slide each low headroom bracket down the top section until top section is tight against wood stop or steel jamb. If a top strut has been installed on the section, the top roller bracket will go between the strut and the section, with the roller above the strut. Line each low headroom top bracket up with the side of the top section. Using both slots in each low headroom bracket as a guide, drill $\frac{5}{32}$ " pilot holes in the center of each slot. Attach top bracket to end stile using (2) $\frac{1}{4}$ -20 x $1\frac{7}{8}$ " carriage bolts & nuts for wood doors or (2) #14 x $\frac{5}{8}$ " sheet metal screws for steel doors. (FIG. 3)

NOTE: Do not tighten fasteners for top brackets all the way until springs are installed and door is ready to be used. This way you will be able to make final adjustments if needed.

You are now ready to attach the springing system to your door.

- For standard Extension Springs, go to section 2A.
- For Front Mount Torsion Springs, go to section 2B.
- For EZ-SET™ Springs, refer to the last page of the green instruction supplement that came with the EZ-SET™ Spring.

Section 2A Standard Extension Spring

NOTE: Cable will extend to bottom bracket on **OUTSIDE** of track.

Step 4

Complete step 1 of the extension spring installation instructions found in the instruction manual provided with your door.

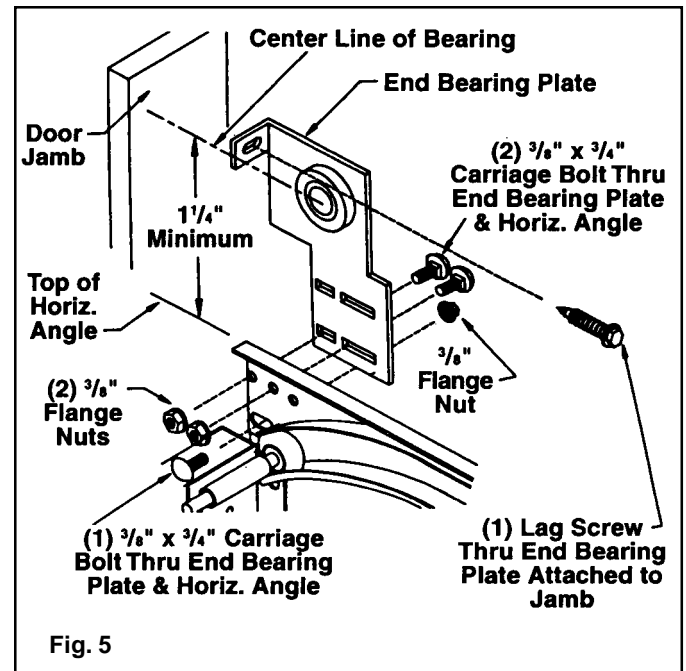
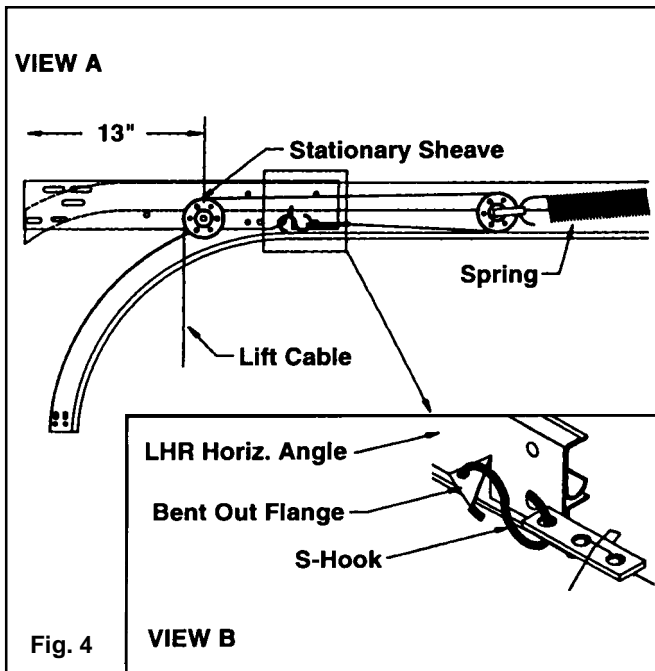

Step 5

Using a 3/8" x 1 1/4" bolt, a 3/8" washer, and a 3/8" nut, attach the stationary sheave to the **outside** of the double track in the position shown in FIG. 4.

NOTE: The head of the bolt must be on the door side.

Step 6

Return to original instruction manual, beginning with step 3 of the extension spring installation instructions.

Section 2B Front Mount Torsion Spring

Step 4

Attach low headroom end bearing plate as shown. (FIG. 5)

Step 5

Install springs, shaft, and cable drums according to FIG. 6.

NOTE: For Double Track Low Headroom, the cable drums are placed outside of the end bearing plates, with the set screws facing out. Also, the RED drum and the spring with the BLACK winding cone are on the left of the center bearing plate, looking out, and the BLACK drum and spring with the RED winding cone are on the right.

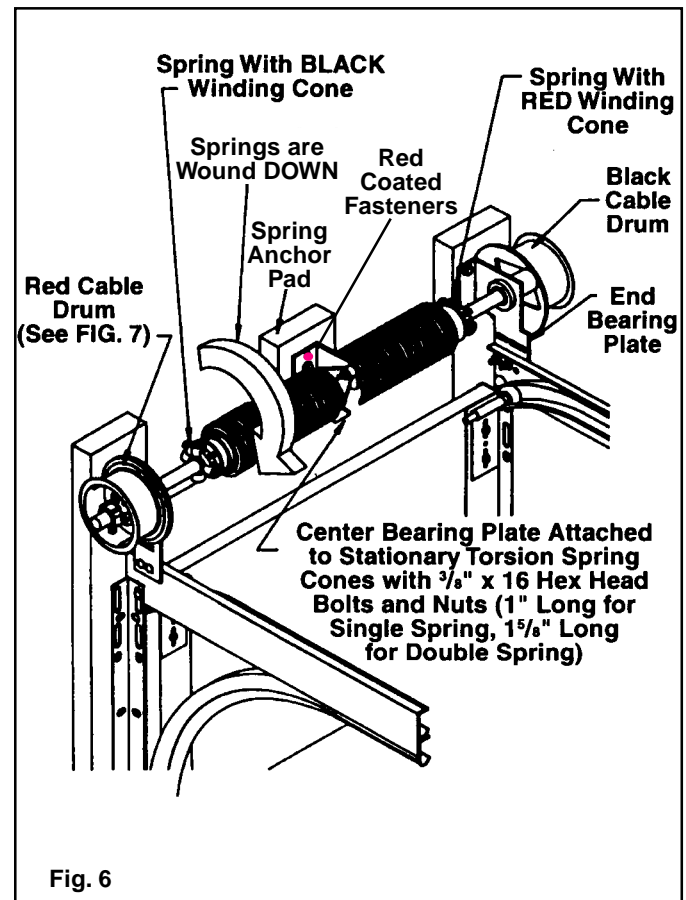

Step 6

Wind the springs according to the procedure found in the original instruction manual.

NOTE: Torsion Springs for Double Track LHR are wound DOWN. (FIG. 7)

Step 7

Push track (if adjustable) towards jambs until door is tight against stop or steel jambs and tighten track bolts.

Step 8

Once all the proper adjustments are made, tighten down the low headroom top bracket fasteners.

