

MODEL 2700

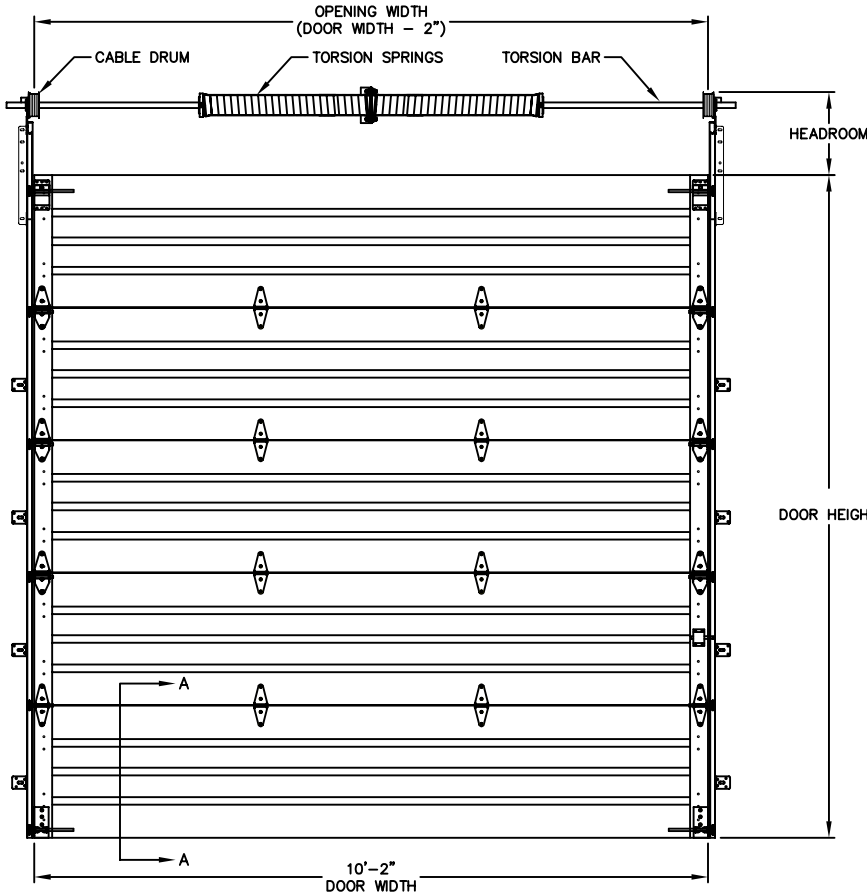

INTERIOR ELEVATION

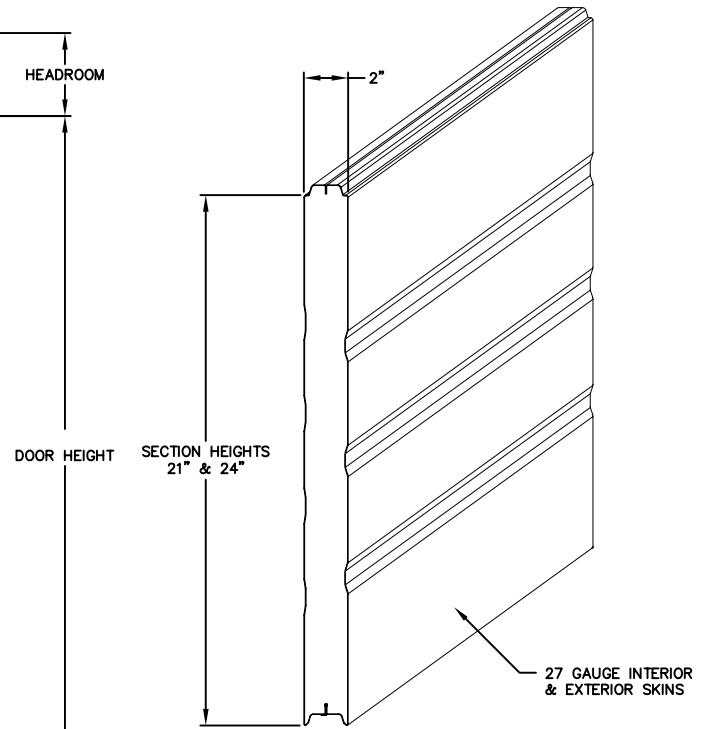

ISOMETRIC PROFILE

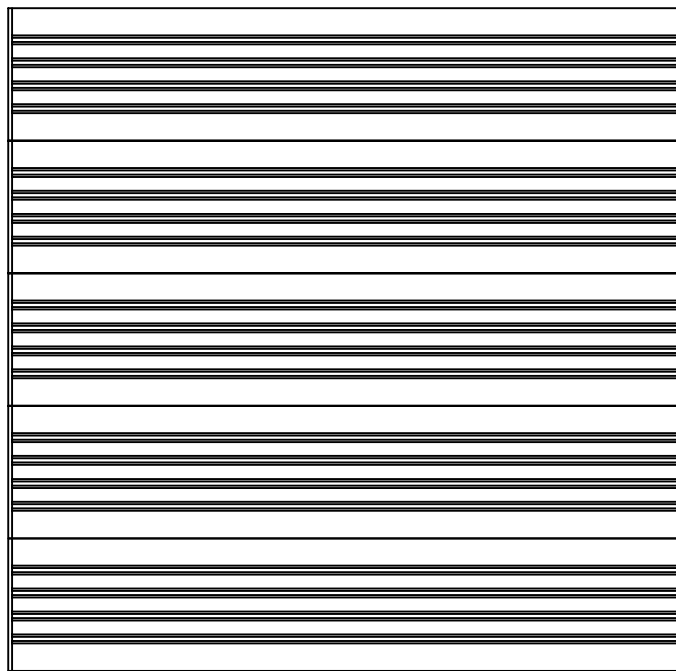

EXTERIOR ELEVATION

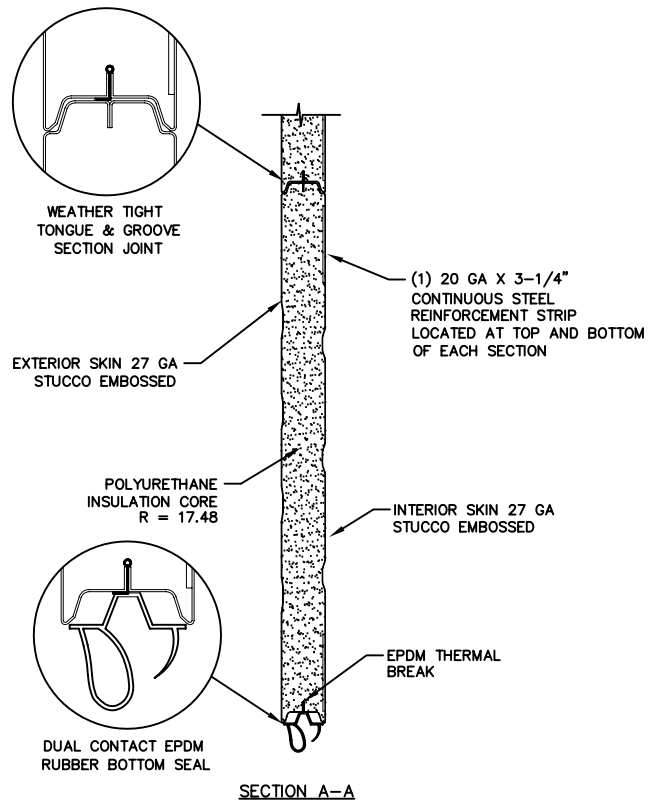

SECTION A-A